



Wilson[®]
VH3100 & 3300
Automatic Vickers/Knoop
Hardness Testers

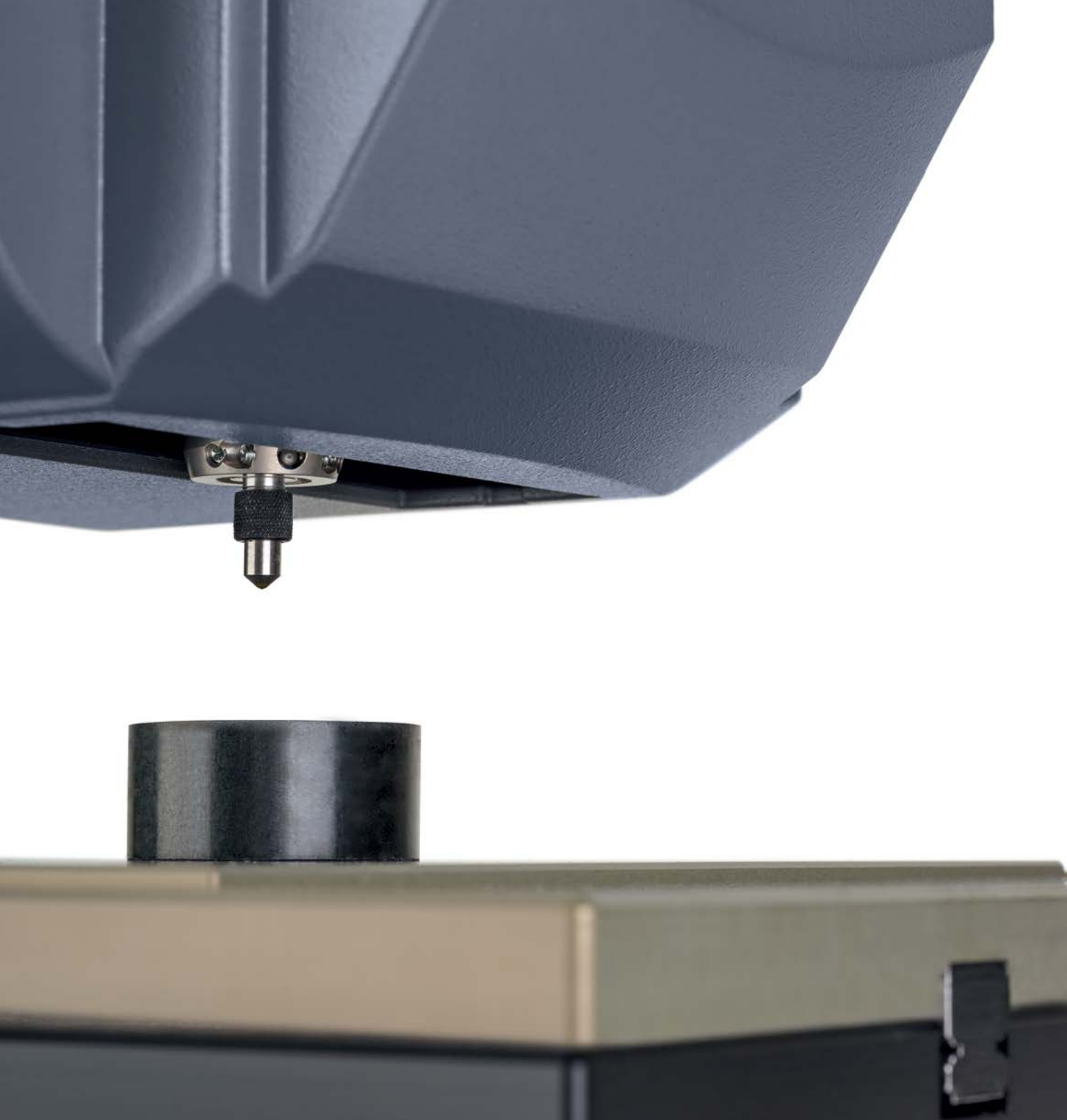

Table of Contents

Wilson VH3100 & VH3300 Overview	3
Excellence in Hardness Testing	5
Customize for your Application	6
Accessories	10
System Overview	12

DiaMet™ Software Overview	15
DiaMet™ Software Features	18
System Configuration Guide	20
Specifications	22



Wilson® VH3100 & VH3300

Automatic Vickers/Knoop Hardness Testers

The Wilson Fully Automated Hardness Testing System provides a fully integrated platform for your complete Vickers and Knoop hardness testing needs. From leading edge modular frame, stage, and optics designs to a fully featured User Interface, our VH3100 and VH3300 Testers can be built to meet your Application needs today, tomorrow, and into the future.

The DiaMet™ Hardness Automation Software provides the User of the VH3100 and VH3300 hardness testers an efficient and fully automated environment to develop and execute tests that maximize the precision of the tester system with the minimum investment of time possible

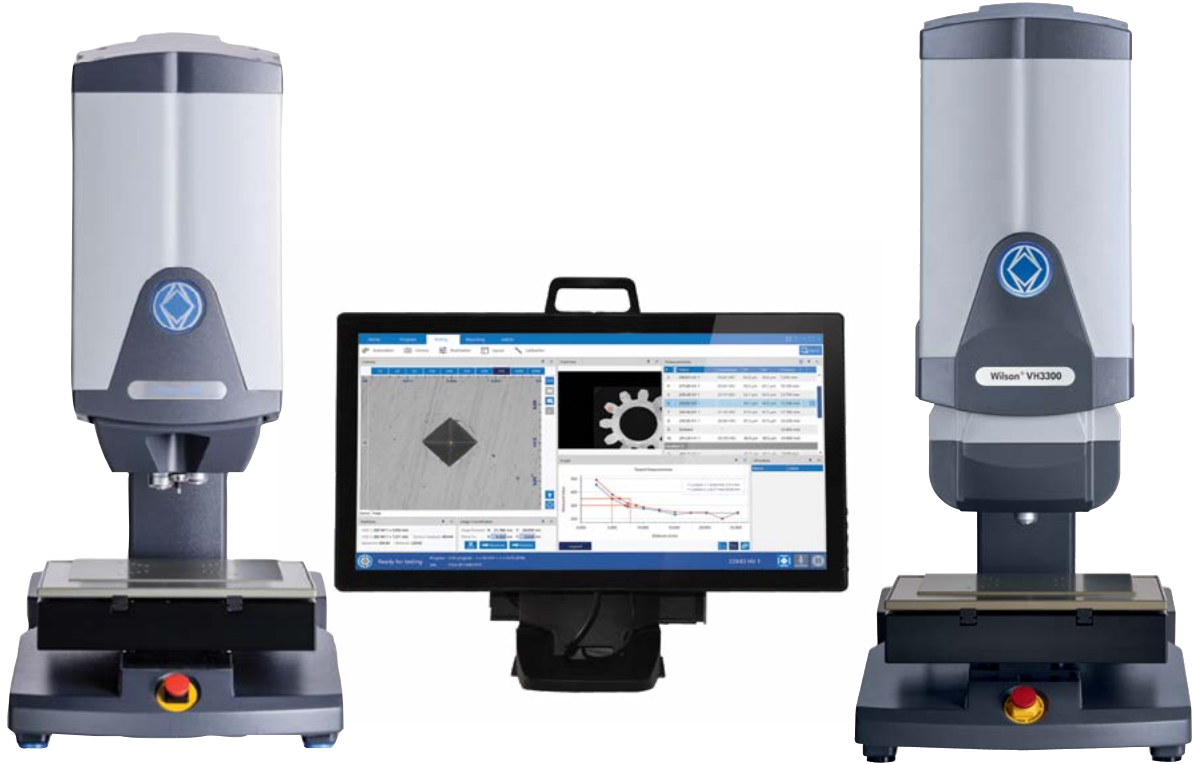

Load Range & Hardness Scales

Load range is important as proper load range and scale is crucial to accurate testing. The Wilson VH3100 tester can accommodate one loadcell and one indenter combination. The wider load range of the Wilson VH3300 can be populated with up to three

loadcells and indenters resulting in a load range of 10gf to 50kgf. This range can be achieved by selecting the low 10N and high 500N load cell.

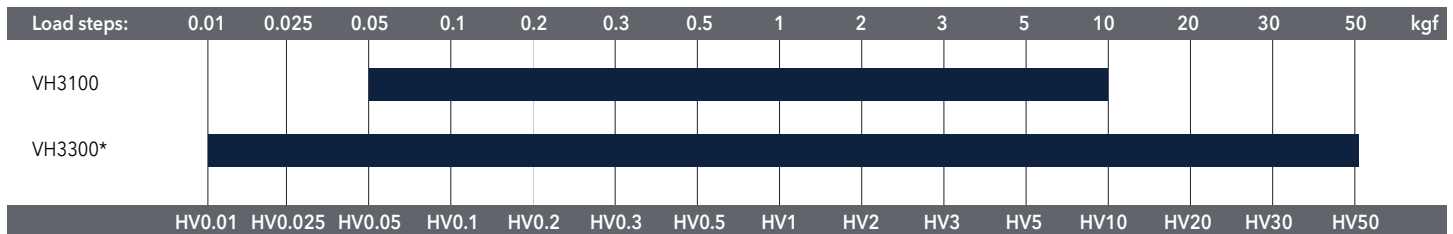

* configuration with one low and one high load loadcell per scale

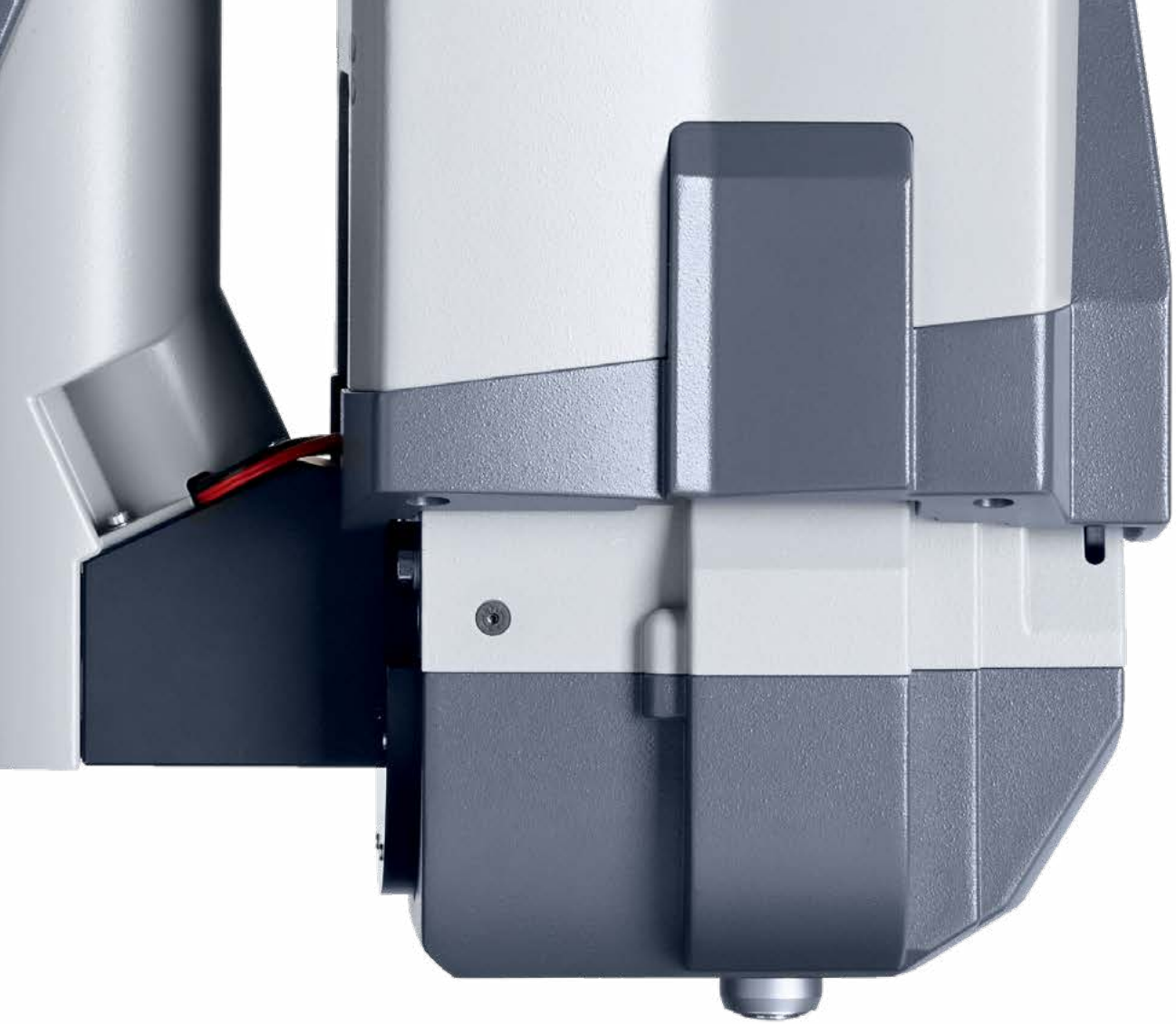

Visit www.buehler.com for more information

Wilson® VH3100 & VH3300

Excellence in Hardness Testing



Wilson Instruments



The trend towards tighter manufacturing tolerances and more advanced heat treatment processes for the aerospace, energy, construction and transportation industries require hardness testing systems to be durable while maintaining precise control during critical test data generation. The system and its interfaces must be easy to use, yet flexible enough to meet the increasing demands of the testing world. The Wilson VH3000 series delivers exceptional performance packaged in a reliable, innovative system that offers superior accuracy, repeatability, improved safety and an overall enhanced user experience.

The global expertise of Buehler is strong as it now includes more than a century of experience from companies such as Wilson Instruments, Wolpert and Reicherter. The Wilson VH3000 series leverages this proud heritage with loadcell measuring systems, instrumentation, controls, accessories and industry preferred software to provide the ultimate high capacity testing platform capable of performing 150 make-and-measure indents an hour using a fully automated test program.

Configurability

The VH3000 Series Testers with DiaMet™ Hardness Testing Automation Software provides you limitless configurability options to match the correct system with your application. Configure the hardware optics and loadcells in the 6 Position Turret to your needs. Configure the DiaMet software layout and functions to match not only your particular application requirements but also needs and preferences of your Operators to maximize their comfort and efficiency.

From color selections, Filar line graphics, and overlay options, the DiaMet Hardness Testing Automation Software is flexible enough to be the interface that you require. The options available through hardware and software configuration allows systems to be tailored to your specific application.

Wilson® VH3100 & VH3300

Customizable for your application

Process control or Research & Development? Most use of hardness testing systems falls into these two categories. Two completely different tasks, both of which need a Vickers/Knoop hardness tester. If the applications are so different, why use the same hardness tester? Buehler provides the solution in the Wilson VH3100 and VH3300.

Tailor the single indenter Wilson VH3100 configuration to fit the 24/7 demands to guard your internal processes and end up with a lean and dedicated hardness tester. Need to expect the unexpected? Or simply have a wide range of customer demands to satisfy? Then the six position turret of the Wilson VH3300 offers you the flexibility to cover the complete Vickers and/or Knoop range with only a few mouse clicks.

Virtual Turret

The single indenter Wilson VH3100 is the fast workhorse of the line, with one indenter, two objectives and optional overview camera. This system significantly reduces system complexity by aligning indenters, objectives and overview camera at a fixed position. All turret positioning is controlled by the high speed stage, while the test head stays stationary. The lack of moving parts, actuators and sensors, simplify adjustments and reduces service needs.



6 Position Star Turret

Those laboratories that need to serve an extremely wide range of applications and those who need to expect the unexpected can be well served with the three indenter Wilson VH3300. Depending on its configuration, this unit can cover a load range from 10grams to 50kilograms. Its fast six position turret also accommodates the optional overview optics.



Collision Resistant System

The Collision Detection System prevents indenter or objective damage by detecting unintended obstructions in the test path. The motion systems are continuously monitored during the test process and system movement is instantaneously stopped if an obstruction is detected. The Collision Detection System provides an unparalleled, unique benefit for operations, while reducing downtime due to damage caused by collision.

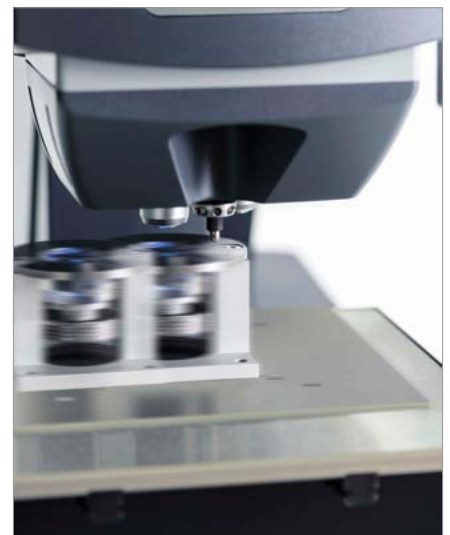

VH3100:	√		√
VH3300:		√	√





Snap Grip

Imagine installing a spare indenter or switching between Vickers and Knoop without any alignment effort. This is achievable with the optional Snap-grip on the Wilson VH3100 as each indenter is prealigned in its own snap-grip holder. Changing indenters is simplified as it can be changed in seconds without the need for tools, set-up or alignment verification.



Closed Loop Load Control

Fast, precise, and reliable testing with a sophisticated closed-loop electronic force measuring system and high precision "in-line" load application mechanics. With all critical parts on one axis and a minimization of moving parts, this closed loop control prevents load overshoot from happening, while compensating for friction and wear over time.

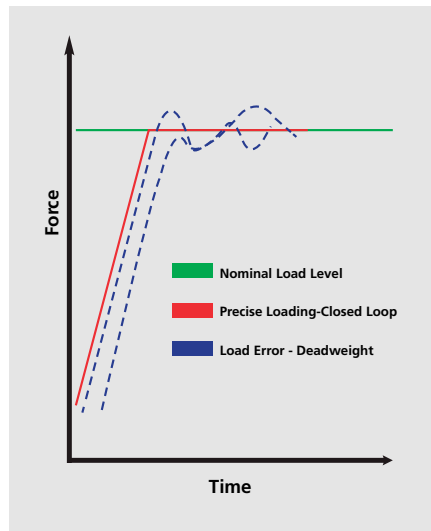

Overshoot protection

Unintentional external influences during the indent process result in a shock, which often is too major for the closed loop system to compensate for. These occurrences would result in inaccurate hardness readings.

The built-in overshoot protection detects load overshoots and aborts the indent process when the maximum test load is exceeded. By doing so, soft readings caused by load overshoots are a thing of the past.



✓	✓	✓	VH3100
	✓	✓	VH3300

Wilson® VH3100 & VH3300

Customizable for your application

Overview Camera & Stitching

The optional built-in high resolution overview camera allows easy navigation over the entire specimen, accurately positions indents and enables photo stitching. The stitch function allows a user to capture their defined area and resolution, then uses the DiaMet™ software to create a composite overview image of one or more parts..

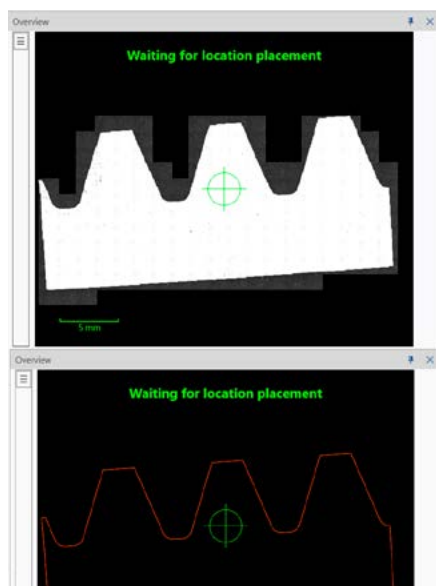

Standard or Touchscreen

The Wilson VH3000 series offers the freedom of choice. For swift and easy “click and run” automated operation, use the rugged, highly responsive touchscreen in a clean production environment. The large, conventional monitor option might be a more suitable solution for large amounts of reporting and result analysis.



Choose Magnification

Selecting the most suitable objectives is made easy with a wide range of objectives and their fields of view. All objectives are monitored by the collision detection system on both Wilson VH3000 models. Each objective can be used at five different zoom steps, allowing you to measure your indents at the optimum size to meet both ISO and ASTM standards.

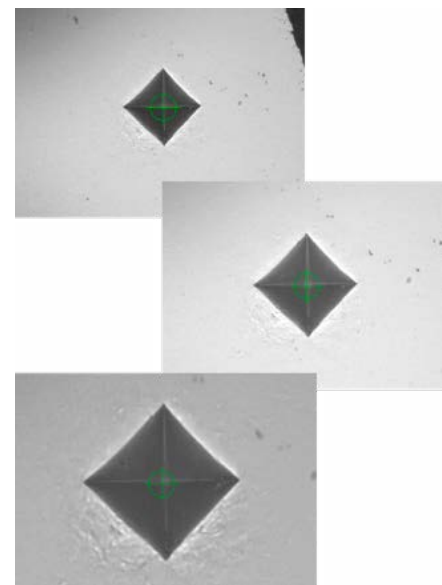

VH3100:	Option	√	2 positions + 5 Zoom Steps per position
VH3300:	Option	√	3 positions*+ 5 Zoom Steps per position



Wilson® VH3100 Application Advantages



Choose a Frame Size

Various applications require various frame sizes. The Wilson VH3100 is available in a compact model, taking up little counter space while providing a test capacity of 4.9in [125mm]. If larger vertical capacity is required, select from the Wilson VH3100 standard frame for 6.7in [170mm] capacity, or the large frame for samples up to 8.5in [215mm].

With 4.1in [105mm] vertical capacity, the Wilson VH3300 is well equipped for testing any mounted sample, welds and other typical hardness specimens. For larger parts the vertical capacity can be increased to 6.1in [155mm].

High Velocity Stage

Save time and improve efficiency with one of the high speed, motorized XY-stages. Available in large or extra-large with travel distances of 7.1x7.1in [180x180mm] or 11.8x7.1in [300x180mm] respectively, these stages enable automated sequencing of multiple samples. The high accuracy and repeatability guarantees precise positioning of indents and allows re-evaluation of all measurement points in the current batch using the camera image.



S, M, L	Configuration option	VH3100
S, M	Configuration option	VH3300

Vickers & Knoop Accessories

Wilson® Test Blocks & Indenters

Wilson test blocks and indenters are available for a wide range of Vickers & Knoop, as well as Rockwell® and Brinell applications. Certified according to ASTM and ISO, we manufacture test blocks in-house to ensure the highest quality test reference standards available. Test blocks and indenters are certified using the latest standardization and optical measuring technology. We operate our own calibration laboratory, traceable to NIST and are accredited to ISO/IEC 17025 by A2LA®.



Choosing the Correct Support

It's important to keep the test specimen stationary during set-up and testing. The correct support will help ensure that the specimen remains motionless.

A wide range of supports are available, whether testing mounted samples, tapered pieces, small diameter parts, wires or sheet metal. Refer to the Buehler Product Catalogue to select the appropriate support for the application.



Multi sample holder



EZ Clamp



Ensure that both the specimen and the support accessory are free of dirt, swarf, oil or corrosion. This is the only way accurate and reliable results are ensured.

For more background information on Vickers and Knoop testing, please refer to the most current edition of the Buehler SumMet book.



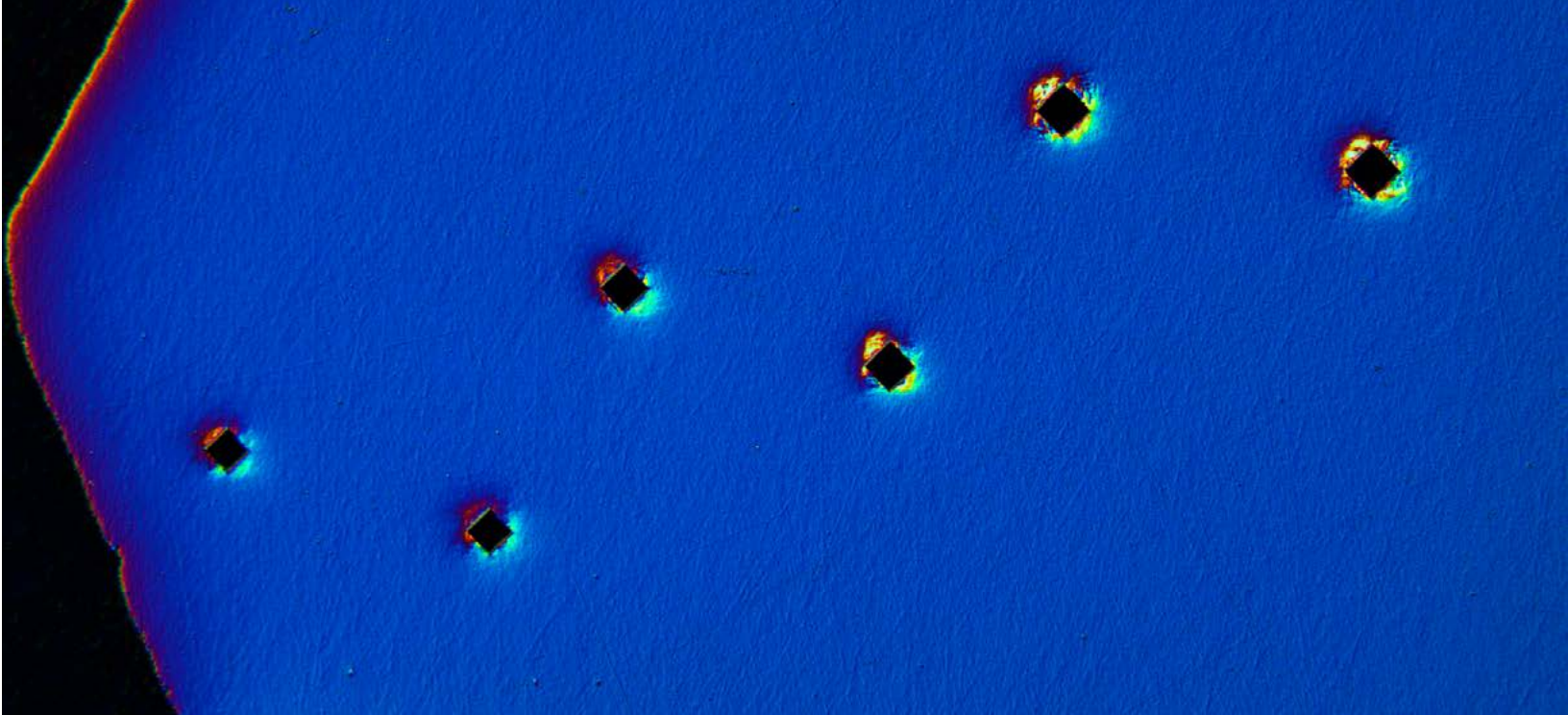

Modular Design

The Wilson® VH3100 was designed with ease of maintenance in mind. This has resulted in a plug and play modular design, where motorized stage, loadcell, controller and test head are easy to exchange in the field. A smart design in combination with tight production tolerances ensure that the modules can be integrated without significant mechanical adjustments. The Windows® based software platform is future proof, and maintained with regular updates.

The many years of experience in designing rugged hardness testers, combined with this new service friendly concept, will reduce downtime, contributing to overall productivity and keeping cost of ownership at a minimum.



Certified

Built in a facility with an accredited ISO 17025 calibration laboratory, the Wilson VH3100 and VH3300 are assembled by fully trained employees following a certified process. Each machine is delivered with a detailed verification report proving the outstanding quality. The calibration procedures form the strong base of our ISO 9001 certified business processes.

For a tracable on-site calibration, please contact your local service representative

Service

Buehler is a worldwide leader in materials preparation and analysis. As your partner in all aspects, we provide not only a complete line of equipment and consumables, but a strong team dedicated to application knowledge, technical support, and when need be, service. With more than 80 locations across the globe offering telephone and email support, training courses, webinars, and one-on-one custom training, Buehler is there to offer support to our customers, industry and applications. Dedicated to your needs, we strive for fast consumable deliveries, efficient service support and 24/7 access to our online preparation guide.

Service - US

+1 800-283-4537
support@buehler.com
or visit service.buehler.com

Service - Europe

+49 0 711 4904690 702
service.eu@buehler.com
or visit service.buehler.com

Service - Asia-Pacific

+86 400 6869 280
service.asia@buehler.com

At a Glance



Wilson® VH3100 & VH3300

Automatic Vickers/Knoop Hardness Testers

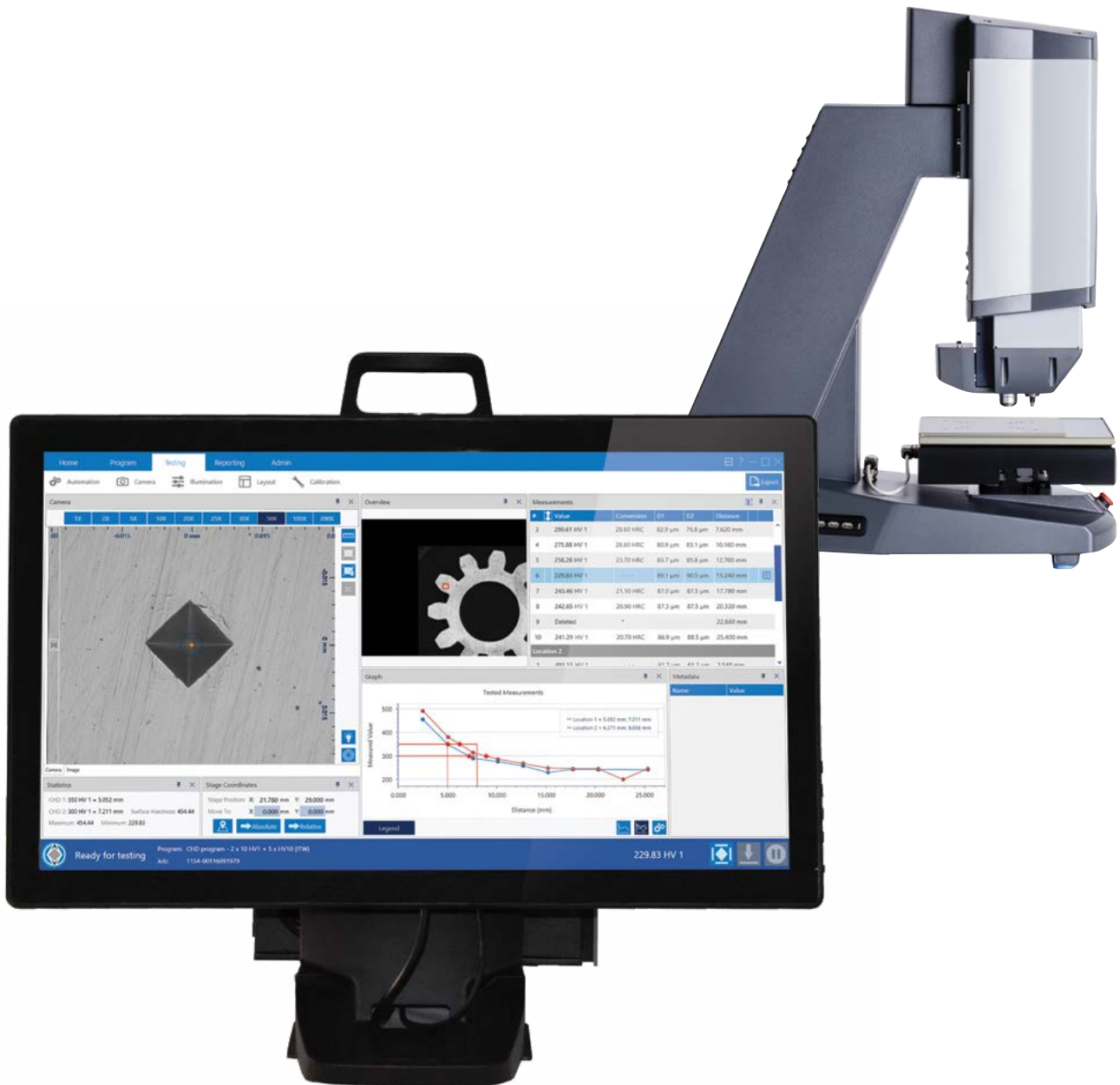

150*
INDENTS PER HOUR

10gf
LOWEST LOAD

50kgf
HIGHEST LOAD

16
LOAD STEPS

6
POSITION TURRET

15
MAGNIFICATION STEPS

* 10s dwell time, depending on load & specimen

DiaMet™

Hardness Testing Made Easy

By removing all unnecessary steps, DiaMet allows users to set-up and run samples in the least possible time. Below is an overview describing a typical workflow within the DiaMet software.

Step 1: Select Program

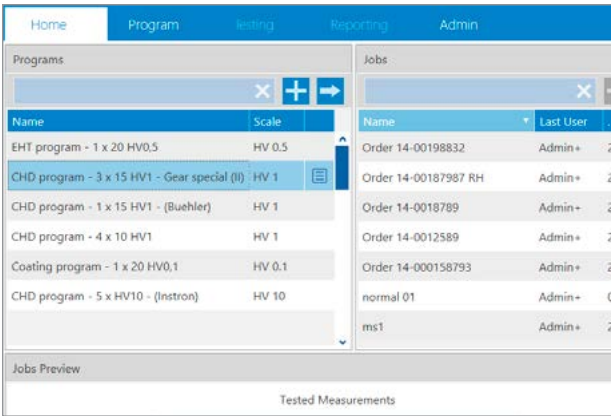

All application specific parameters like scale, dwell time, pattern, conversion & report template are stored in the same program.

Step 2: Position Pattern

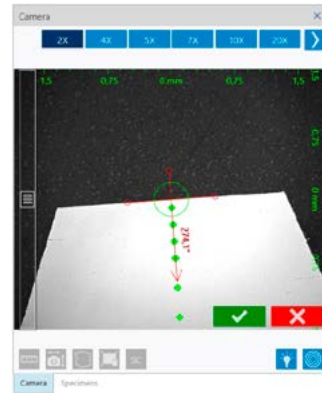

Use the overview camera or infinite scan to see where all indents will be placed. Press start to indent and measure all.

Step 3: Indent & Measure

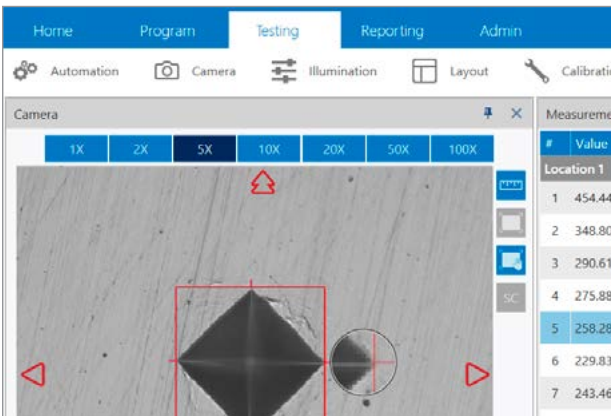

Machine & software make all indentations & measure them automatically, with use of the standard* automatic focus, automatic illumination and automatic measurement functions.

Step 4: Evaluate

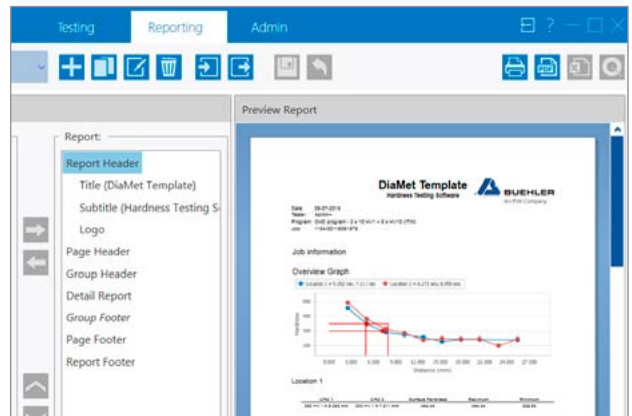

Verify the readings in graph and grid and remeasure or re-indent where applicable. Export results to PDF, printer or Excel®.

* On fully automatic configurations.





Automation

Often a high level of automation comes with a high level of complexity both in setup and in operation. Breaking convention, the DiaMet™ software focuses on fast and simple operation to compensate for less experienced operators while still offering a high feature set and flexibility required by expert users. Once a required test pattern is setup, any operator can run the series of Vickers or Knoop indents with a minimum of four clicks or four touches depending on the monitor options.

Speed

Developed by the same team, the Wilson VH3000 series testers and DiaMet software are completely complimentary to one another. This perfect fit results in the fastest test cycle, fastest auto-focus and fastest auto-measure sequence. By delivering accurate results faster, the user is able to either quickly focus on and control internal processes or perform additional tests.

Safety

The Collision Detection System prevents indenter or objective damage by detecting unintended obstructions in the test path. The motion system is continuously monitored during the test process and system movement is instantaneously stopped if an obstruction is detected. The Collision Detection System provides an unparalleled, unique to market essential safety benefit for operators, while reducing downtime and maintenance costs.

4 clicks

to run an automated test

5 seconds

or less for Auto-focus & Automeasure

Collision Detection

Indenters & Objectives

Versatile

DiaMet is optimized for evaluating Macro-Vickers, Micro-Vickers and Knoop indents according to ISO 6507, ISO 4545, ASTM E384 and ASTM E92 as well as Brinell measurements according to ISO 6506 and ASTM E10 standards. A standard DiaMet feature is an automatic symmetry calculation for Vickers, Knoop and Brinell indents. This extra validation, with clear visual indication, helps to ensure the results conform to standards.

Brinell

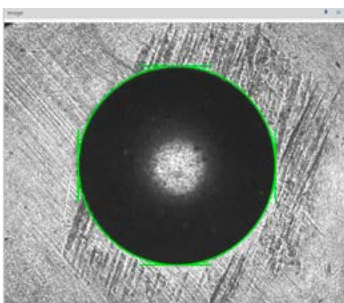

Knoop

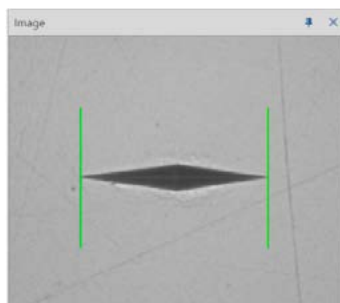

Vickers

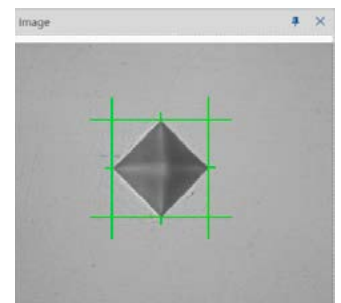

Intuitive & Touch Optimized

Navigating the DiaMet™ software is easy with its clear design and simple and intuitive organization. Tabs on the top of the screen organize primary tools and allows for switching between them. Secondary selections operate in the same fashion, while the status bar provides comprehensive feedback on test progress. With an entirely new look and feel designed for touch panel use, the DiaMet software is simple, useful and smart to work with.

Flexible UI

Use the functions you need - fully configurable

Measurement

State-of-the-art algorithms ensure quick and effective illumination, focus and auto-measure

Overview

Use the overview window for specimen navigation and pattern placement

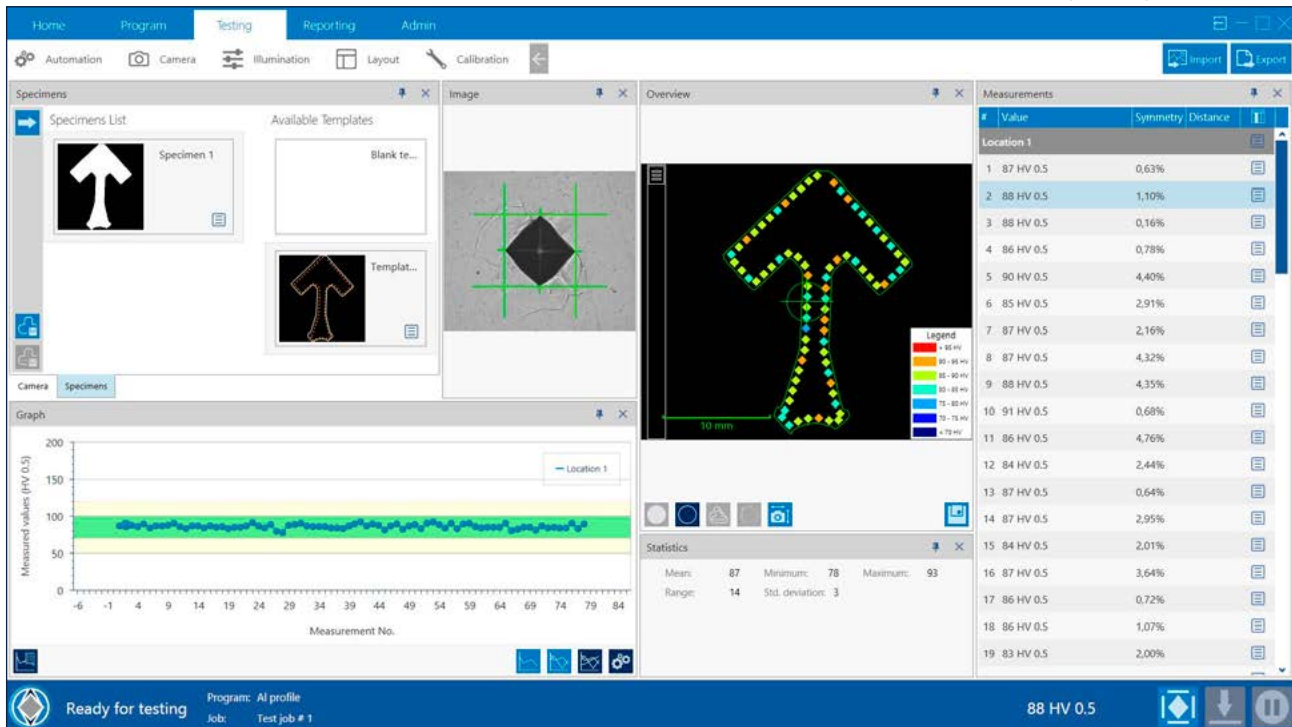

Specimens

Scan your samples and save them as templates - automatic pattern placement

Status Bar

Total test time and indent counter - plan your test cycles

Data Management

Review and manage your test data with easy access

QuickTest

The fastest results can be produced using QuickTest. The user can save programs on the opening screen of Diamet. Selecting a program brings the user directly to the measurement screen, with all the predetermined parameters set and immediately ready to make indents. QuickTest programs can be password protected to prevent unauthorized use or changes.

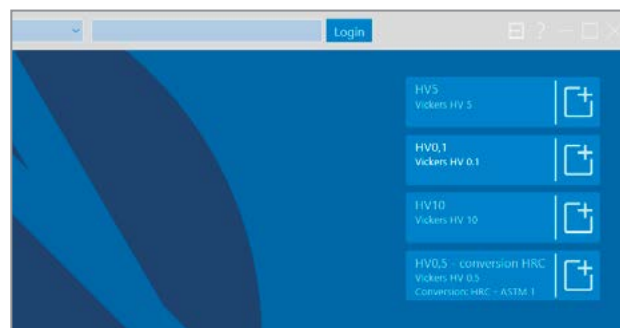



Easy Handling

Graphical Pattern Editor

The DiaMet™ pattern editor allows the user to create any number of patterns with a large number of variables. Create patterns with great precision and verify the result in the preview. Combine different patterns and even different loads in one program, and run them fully automatically.

For example 3 CHD rows of 15 indents with HV1, and a core hardness determination out of an average of 5 indents HV10. This is the level of flexibility the VH3000-series offers.

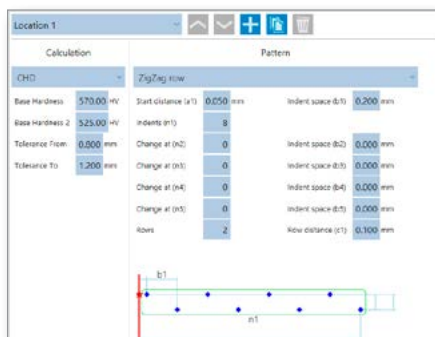

Create
to run an automated test

Macro View / Navigation Map

Using the Macro view function, it's possible to create a composite image of the specimen. The shape and size of the specimen is irrelevant, since the DiaMet software can scan any area within stage limits.

Blend in the overview window to navigate quickly and efficiently from test location to test location.

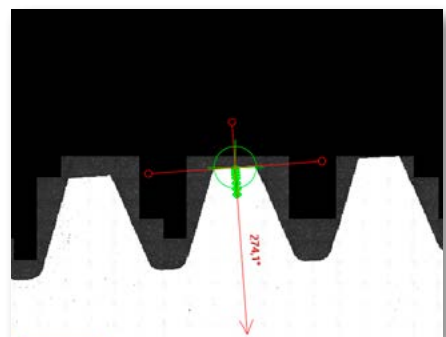

Navigate
on the sample

Pattern Image Overlay

DiaMet shows the operator where the indents will be made, even before the actual indent process takes place.

The pattern image overlay function helps whilst positioning multiple test rows all across the specimen. The pattern video overlay scales automatically with every magnification, even within the macroview.

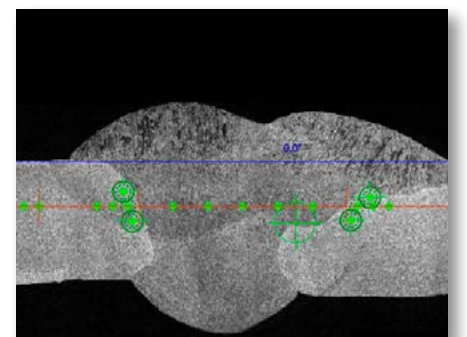

See
where to place indent

Software Features



Auto-Illumination

Repeatable, repeatable, repeatable - the DiaMet™ software automatic illumination adjusts to the correct illumination level on whatever sample, wherever on the sample independent from material (steels, tool steels, carbides, coatings).

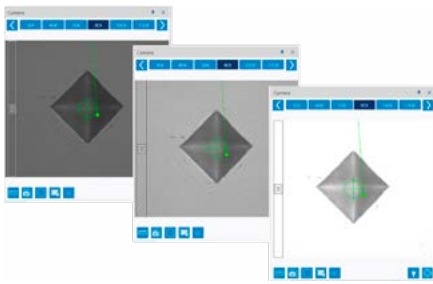

Repeatable
Brightness & Contrast



Auto-Focus

Astonishing- observe how the software finds focus from a distance as far away as 30mm or more. Enjoy the sheer Auto-Focus-speed when focusing at close range. The DiaMet software Auto-Focus algorithm sets new standards.

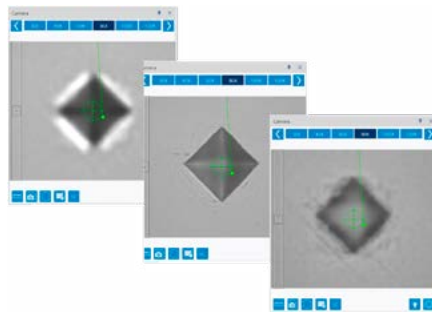

Repeatable
Sharpness



Auto-Measurement

Manual positioning of filar lines is no longer required with the DiaMet software's refined measurement algorithm. Maintain control by switching to manual measure mode and adjust measurements by touch or mouse. Enable the automatic indent symmetry check on demand for further standards confirmation.

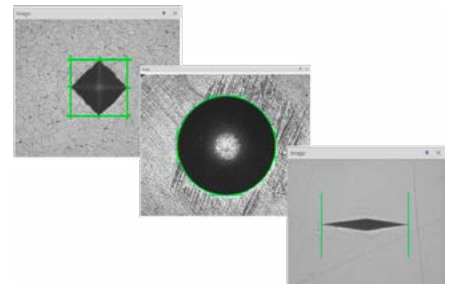

Repeatable
Results



Dual Monitor Option

Having two screens revolutionizes the way you work allowing you to display all graphs and results on, one screen while operating the hardness tester and evaluating indents on the other. With the flexibility offered by DiaMet one can configure the dual monitor according to personal preference.





Configure your personal layout, accessing as many measurement aids on the screen as needed. Filar lines can be colored to achieve the best contrast to your specimen, a ruler can be added to provide reference during navigation and positioning, and you can pop up the magnifier glass to help manually position the filar lines.

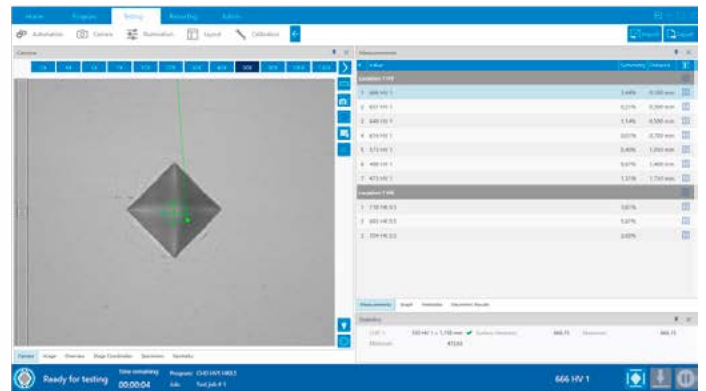
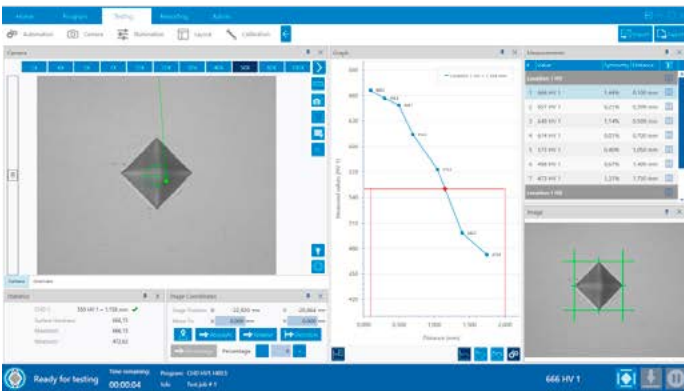
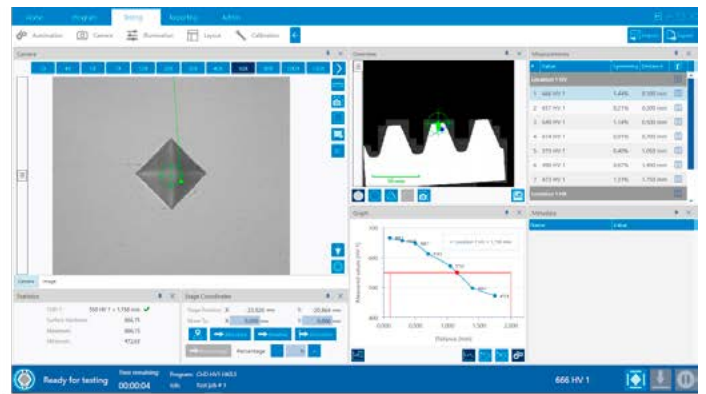
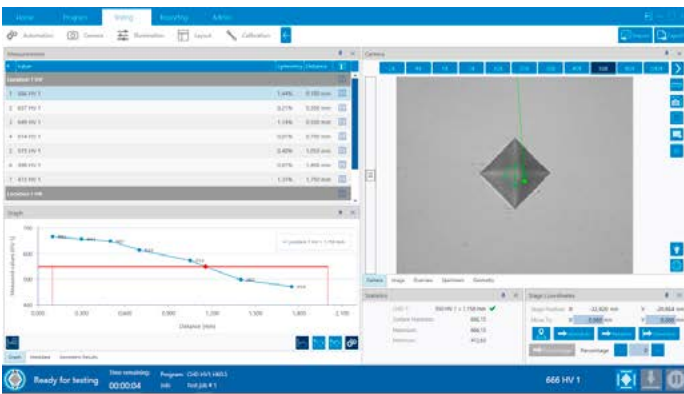

System Configuration

Start by selecting either the VH3100 or VH3300 and continue on to create a customized Vickers-Knoop Hardness tester

Main Unit



Wilson VH3100

- 3+1 position virtual turret
- 0,050 - 10kgf load range

W3111



Wilson VH3300

- 3+3 position motorized turret
- 0,010 - 50kgf load range*

**depending on configuration*

W3210

Software Options

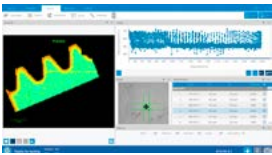

DiaMet Full-Automatic software package

W3100A03

DiaMet Enterprise software package

W3100A15

DiaMet Full-Automatic software package

W3100A03

DiaMet Enterprise software package

W3100A15

Monitors



24" Touch screen

W3100B03

24" Full HD monitor

W3100B04

24" Touch screen

W3100B03

24" Full HD monitor

W3100B04

Motorized Stages

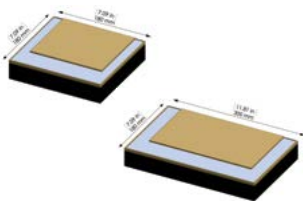

Standard size

- 180 x 180mm

W3100C02

Large size

- 300 x 180mm

W3100C03

Standard size

- 180 x 180mm

W3200C02

Large size

- 300 x 180mm

W3200C03

Vertical Test Capacity



Height 125mm - W3100-D01

Height 170mm - W3100-D02

Height 215mm - W3100-D03

Height 105mm - W3200D01

Height 155mm - W3200D02



System Configurations *(Continued)*

Wilson VH3100

Wilson VH3300

Overview Camera



- Separate overview camera
- Includes Scan & Stitch function in the DiaMet software

W3110F01

- Turret integrated overview
- Includes Scan & Stitch function in the DiaMet software

W3200F01

Load Cell

select one for VH3100,
select between one and
three for VH3300

W3100E02 - 100N loadcell

W3210E01 - 10N loadcell
W3200E02 - 100N loadcell
W3200E04 - 500N loadcell

Scales	HK0.01	HK0.025	HK0.05	HK0.1	HK0.2	HK0.3	HK0.5	HK1	HK2									
	HV0.01	HV0.025	HV0.05	HV0.1	HV0.2	HV0.3	HV0.5	HV1	HV2	HV3	HV5	HV10	HV20	HV30	HV50			

Wilson VH3100	Loadcell W3100E02																		
Wilson VH3300	W3210E01																		
											W3200E02								
																W3200E04			

Additional Accessories

For Indenters select one Indenter per Load Cell.
For Objectives select up to two for VH3100, select two or three for VH3300



**for VH3100 Only*

Indenter Holder*

Standard holder
W3100G01
SnapGrip Holder
W3100G02



Vickers Indenter

Vickers Indenter, ISO & ASTM
Certified
W9100687



Knoop Indenter

Knoop Indenter, ISO & ASTM
Certified
W9100684



Objectives

W5XLWD 5x LWD FOV: 3600µm
W10XLWD 10x LWD FOV: 1800µm
W20XLWD 20x LWD FOV: 900µm
W40XLWD 40x LWD FOV: 450µm
W50XLWD 50x LWD FOV: 360µm
W100XLWD 100x LWD FOV: 180µm

Technical Specifications



Approx. Weight: 82.7 lbs [37.5kg]

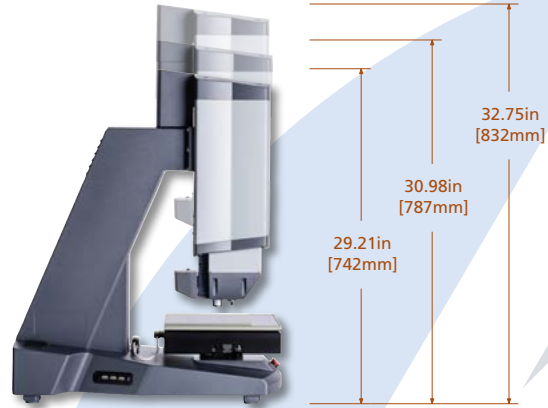

Wilson VH3100

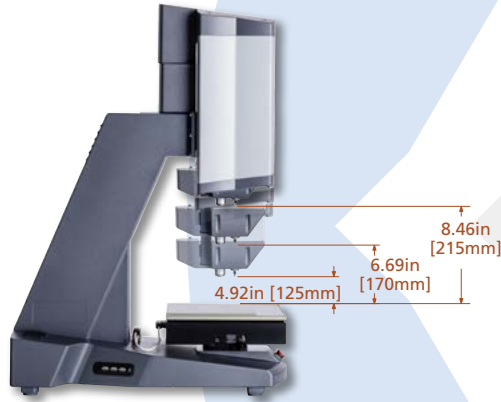

Wilson VH3300

	Wilson VH3100	Wilson VH3300
Scales		HV, HK
Turret	Automatic 3 position + overview	Automatic 6 position incl. overview
Indenter positions	1 (optional with SnapGrip)	upto 3 (select)
Test Load (select)		Small loadcell (10N) 10gf - 1kgf
		Medium loadcell (100N) 50gf - 10kgf
		Large loadcell (500N) 0,5kgf - 50kgf
Test Load Accuracy	$\pm 1.5\% < 200g, \pm 1\% > 200g$	
Force Application	Load Cell	
Dwell Time	1 - 999 seconds	
Standard Compliance	ASTM E384, E92; ISO 6507, 9385, 4545	
Magnification Range	30X - 2000X with digital zooming	
Overview Camera (optional)	0.5 x 0.5in [13 x 13mm]	0.25 x 0.25in [6 x 6 mm]
Light Source	LED	



Stage Option Specifications

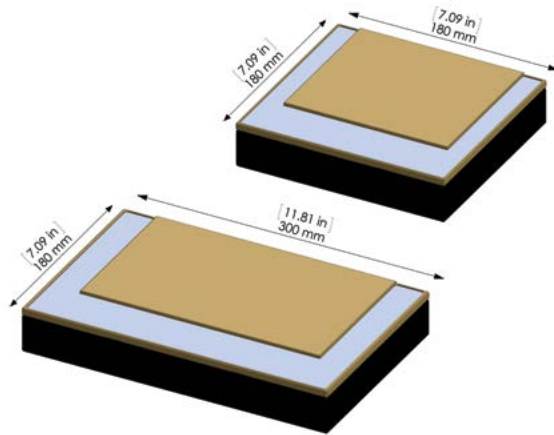

	Large Stage	Extra Large Stage
Travel	7.08 x 7.08in [180 x 180mm]	11.8 x 7.08in [300 x 180mm]
Effective Workspace VH3100	5.5 x 5.7in [140 x 145mm] (5.5 x 4.3in [140 x 110mm] with over- view camera)	10.2 x 5.7in [260 x 145mm] 10.2 x 4.3in [260 x 110mm] with over- view camera)
Travel Speed	1.06in/s [24mm/s] (XY)	
Physical Resolution	0.5µm	
Repeatability	Better than 5µm	
Accuracy	Absolute accuracy in µm: measuring length in mm / 3 + 5 (from target centre)	
Weight	±22.0 lbs [±10kg]	±30.8 lbs [±14kg]
Overall Size	11.02 x 10.23 x 2.75in [280 x 260 x 70mm]	15 x 10.23 x 2.75in [380 x 260 x 70mm]

Environmental Conditions

Operating Temperature	50 - 100°F [10 - 38°C] (Note: ISO & ASTM standards recommend 68 - 79°F [20 - 26°C])
Humidity	10 - 90% non-condensing
Power	100-240VAC, 50/60Hz
Weight	VH3100: 82.7 lbs [37.5kg] incl. 180x180 stage, without monitor VH3300: 144lbs [65kg] incl. 180x180 stage, without monitor

NADCAP and Buehler

Buehler developed many methods to simplify material preparation and analysis for NADCAP accredited customers. The traceability of hardness testing machines is a very important step for materials inspection. In order to ensure all testing is performed by a verified machine, indirect verification needs to be performed on hardness reference blocks. Respective blocks are calibrated in accordance with ISO and ASTM standards, as well as engraved with a grid on the top surface, which allows each verification test to meet indent spacing requirement.

To ensure all verification measurements are performed as required (e.g. at a specific time, after scale change, after indenter change etc.) , Buehler developed a special software module within the DiaMet hardness software. The verification program will prompt operators to perform indirect verification tests as required. This way, full traceability is guaranteed and is clearly exhibited during audits. For additional information contact your sales representative.

Buehler Worldwide Locations

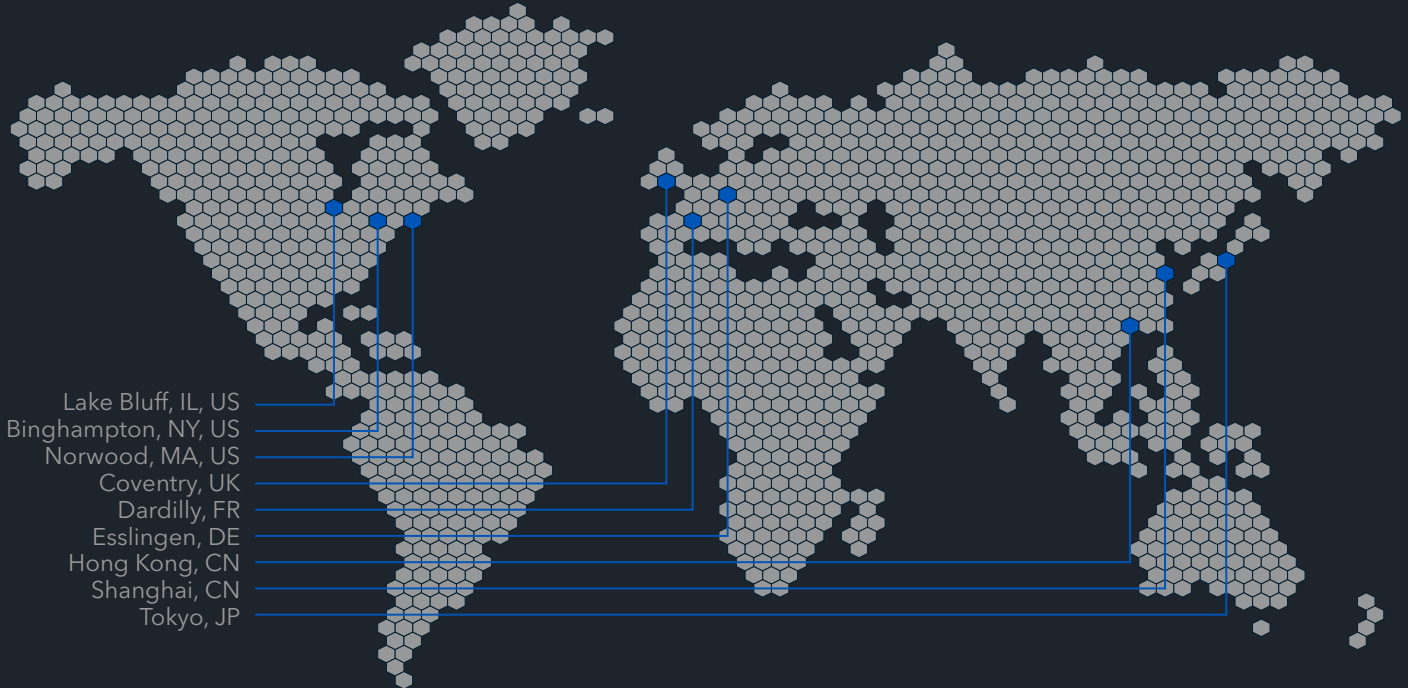

BUEHLER

Strong Partner, Reliable Solutions

BUEHLER

41 Waukegan Road, Lake Bluff, Illinois 60044

P: +1 847 295 6500 | 800 BUEHLER (800 283 4537)

W: www.buehler.com | **E:** info@buehler.com

North America-South America Offices

BUEHLER Worldwide Headquarters

P: +1 847 295 6500 | 800 BUEHLER (800 283 4537)

W: www.buehler.com | **E:** info@buehler.com

Europe Offices

BUEHLER Germany - Esslingen

ITW Test & Measurement GmbH

European Headquarters

P: +49 (0) 711 4904690-0

E: info.eu@buehler.com

BUEHLER France - Dardilly

P: +33 (0) 800 89 73 71

E: info.eu@buehler.com

BUEHLER United Kingdom - Coventry

P: +44 (0) 800 707 6273

E: info.eu@buehler.com

Asia-Pacific Offices

BUEHLER China - Shanghai

ITW Test & Measurement (Shanghai) Co., Ltd.

Asia Headquarters

P: +86 400 111 8683

E: info.cn@buehler.com

BUEHLER Japan

P: +81 03 5439 5077

E: info.japan@buehler.com

BUEHLER Asia-Pacific

P: +86 400 111 8683

E: info.asia@buehler.com

Visit www.buehler.com for more information on a Buehler location near you.

